

8.6 Exploded view of a typical Rochester 2G series carburetor

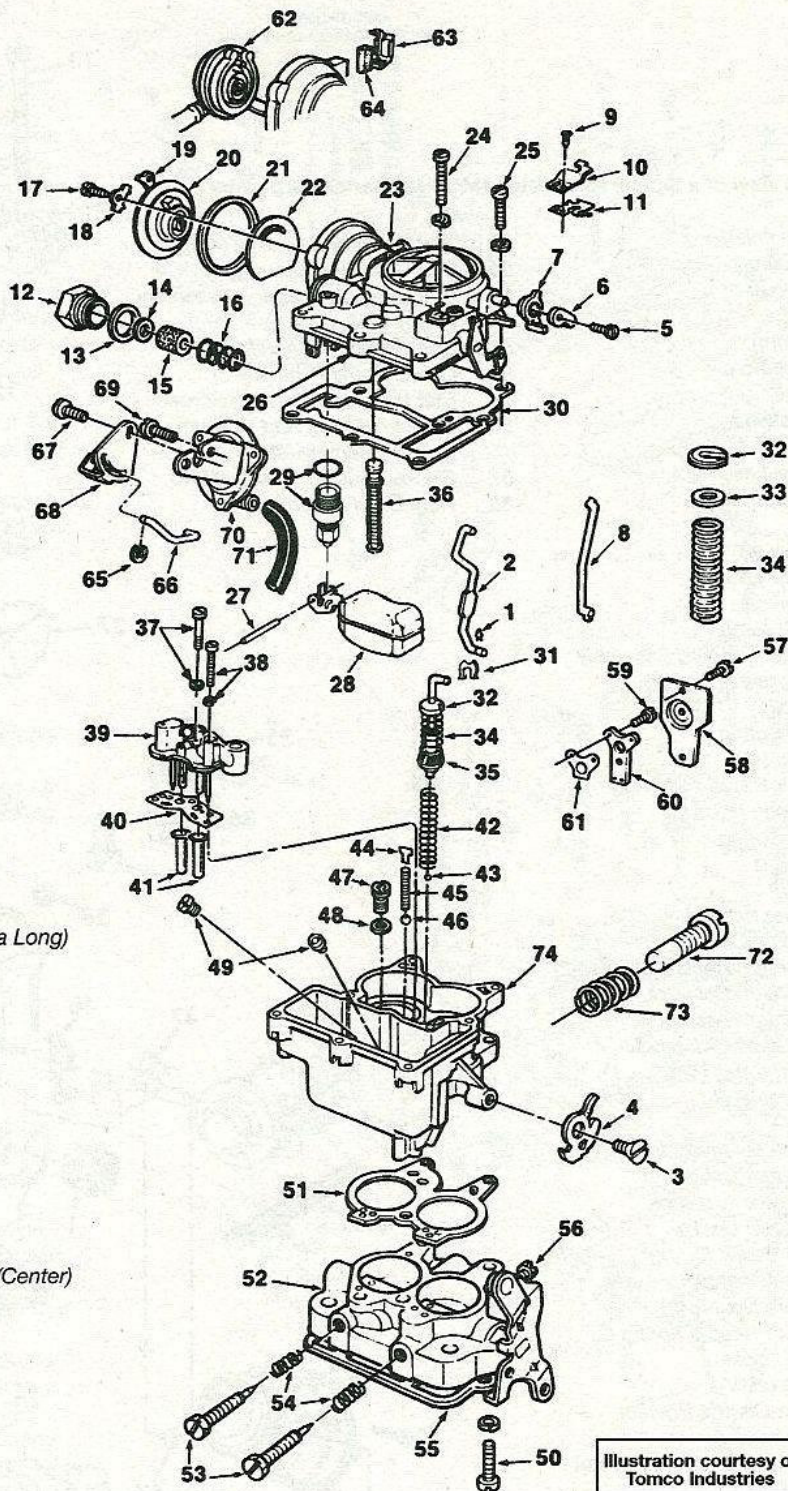

- 1 Pump Rod Retainer
- 2 Pump Rod
- 3 Fast Idle Cam Screw
- 4 Fast idle Cam
- 5 Trip Lever Screw
- 6 Trip Lever
- 7 Choke Lever and Collar
- 8 Choke Rod
- 9 Idle Vent Valve Screw
- 10 Idle Vent Valve Shield
- 11 Idle Vent Valve
- 12 Fuel Inlet Fitting
- 13 Fuel Inlet Fitting Gasket
- 14 Fuel Filter Gasket
- 15 Fuel Inlet Filter
- 16 Fuel Filter Spring
- 17 Stat Cover Retainer Screw
- 18 Stat Cover Toothed Retainer
- 19 Stat Cover Plain Retainer
- 20 Stat Cover & Spring Assembly
- 21 Stat Cover Basket
- 22 Choke Baffle Plate
- 23 Choke Housing Basket (Not Shown)
- 24 Bowl Cover Screw & Lockwasher (Extra Long)
- 25 Bowl Cover Screw & Lockwasher
- 26 Bowl Cover Assembly
- 27 Float Hinge Pin
- 28 Float Assembly
- 29 Rotary Inlet Valve & Gasket
- 30 Bowl Cover Gasket
- 31 Pump Plunger Retainer
- 32 Pump Plunger Lock Ring
- 33 Pump Plunger Washer
- 34 Pump Plunger Spring
- 35 Pump Plunger Cup
- 36 Power Piston Assembly
- 37 Venturi Cluster Screw & Fiber Washer (Center)
- 38 Venturi Cluster Screw & Lockwasher
- 39 Venturi Cluster
- 40 Venturi Cluster Gasket
- 41 Main Well Inserts
- 42 Pump Return Spring
- 43 Pump Check Ball
- 44 Pump Discharge Ball Guide
- 45 Pump Discharge Ball Spring
- 46 Pump Discharge Ball
- 47 Power Valve Assembly
- 48 Power Valve Assembly Gasket
- 49 Main Metering Jets
- 50 Throttle Body To Bowl Screw & Lockwasher
- 51 Throttle Body Gasket
- 52 Throttle Body & Shaft Assembly
- 53 Idle Needles
- 54 Idle Needle Springs
- 55 Flange Gasket
- 56 Idle Adjust Screw

- 57 Idle Compensator Cover Screw
- 58 Idle Compensator Cover
- 59 Idle Compensator Valve Screw
- 60 Idle Compensator Valve
- 61 Idle Compensator Valve Gasket
- 62 Hot Water Choke Assembly
- 63 Hot Water Filter Retainer
- 64 Hot Water Filter
- 65 Vacuum Control Rod Retainer

- 66 Vacuum Control Rod
- 67 Stat Rod Lever Screw
- 68 Stat Rod Lever
- 69 Vacuum Control Attaching Screw
- 70 Vacuum Break Control Assembly
- 71 Vacuum Break Control Hose
- 72 Idle Air Adjust Needle
- 73 Idle Air Adjust Needle Spring
- 74 Bowl Assembly

Illustration courtesy of Tomco Industries